

Specification Document

**Water leakage detection sensor cable**

Position Detection Water Leakage Sensor

AD-LS

**TASHIKA CO., LTD.**

1-12, Kaiyo-cho, Ashiya, 659-0035, JAPAN

Tel: + 81-797-23-9035

Fax: + 81-797-23-2105

e-mail: [sales@tashika.co.jp](mailto:sales@tashika.co.jp)

URL: [www.tashika.co.jp](http://www.tashika.co.jp)

## <<<Important safety instructions>>>

### **Warning**

Improper handling of the sensor in non-compliance to any of the following warning precautions or instructions given on a WARNING label can result in death, serious injury, fire, electric shock, and/or sensor failure.

#### Warning Precautions

##### Strictly Prohibited !

- Never use the sensor as electric cable.

##### Confirm !

- The sensor length must not exceed 100 m per circuit.
- Handle the sensor carefully; it will not work if soiled or damaged.
- Take precautions to ensure the sensor does not become wet.
- Before use, be sure to read the precautions on the rear of the sensor case.

##### Caution on Installation !

- Do not install the sensor directly on any surface where dew can form.
- Attach the sensor as tightly as possible to the mounting surface. Any unavoidable gap such as on an uneven floor or the like horizontal surface must not exceed 2 mm, and on a pillar, beam or the like vertical surface the gap must not exceed 1 mm.
- To minimize the influence of external electromagnetic induction, the sensor comprises two electrodes twisted in a braid form. However, avoid installing the sensor over a long distance in parallel with a power cable or other electromagnetic induction sources.
- Where the sensor intersects a power cable of 300 V or higher service voltage, surround the sensor completely with an insulating protective barrier, such as plastic molding.
- Install the sensor so that it can be easily replaced. After detection of water leakage, the sensor is reset when the water has evaporated. However, if the sensor absorbs water that contains conductive or water-repellent material, it possibly cannot be reset and needs to be replaced.
- To prevent electrical corrosion of the sensor, be sure to connect it to an alternate-current water leakage detector.
- Do not allow wax or other oil-based material on the sensor; water is repelled from the surface and may not be detected.

## Table of contents

	Page
1. Scope .....	1
2. Construction .....	1
3. Specifications .....	2

## 1. Scope of Application

The specification document is applicable for the water leakage position detection sensor (AD-LS sensor). It is developed to detect the water leakage position rapidly.

## 2. Construction

Fig. 1 and Fig. 2 show the construction of the AD-LS sensor.

- Electrode 1 (red): In the  $0.33\text{mm}^2$  strand of tinned annealed copper wire woven by polyethylene
- Electrode 2 (blue): In the  $0.5\text{mm}^2$  strand of tinned annealed copper wire insulated by FEP
- Electrode 3 (white): There is polyethylene on the resistance wire
- Outer sheathing: Polyester

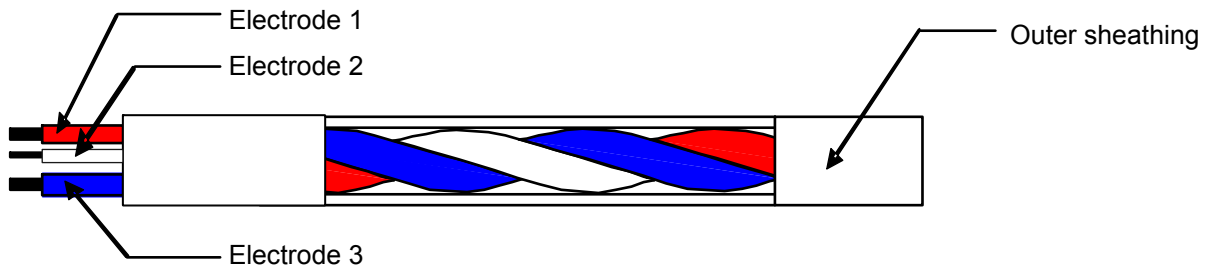

Fig. 1: Schematic Diagram of the AD-LS Sensor

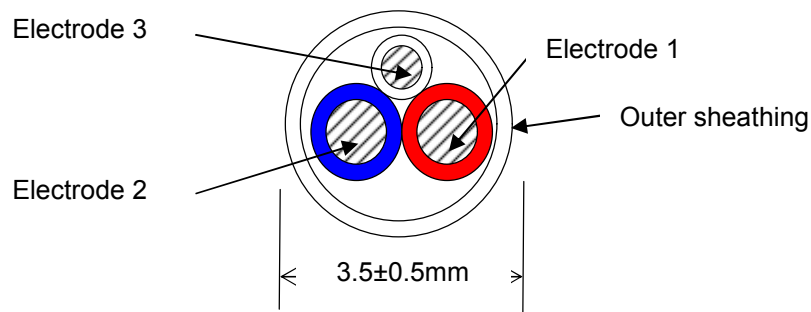

Fig. 2: Cross-section Diagram of the AD-LS Sensor

