

Fiber Type Infrared Thermometer

FTZ9 series





FEATURES

By using fiber unit, the setting becomes easier avoiding the bad environments.
 Sensor head is small and lightweight and its heat-resistant temperature is 150 (But Converter : 70)
 By LED, laser, optical sight, the point whose temperature is detected becomes clear.
 High Speed Response : Only 1msec. (Depending on the model.)
 Measuring range : 220 ~ 5,000 (Heavy Selling Models 2 types, Standard Models 6 types)

Downsizing 1/4!

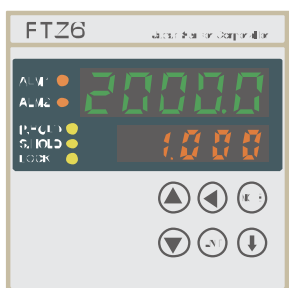

FTZ6 96mm×96mm



48mm×48mm

Sensor unit works without Indicating Setter

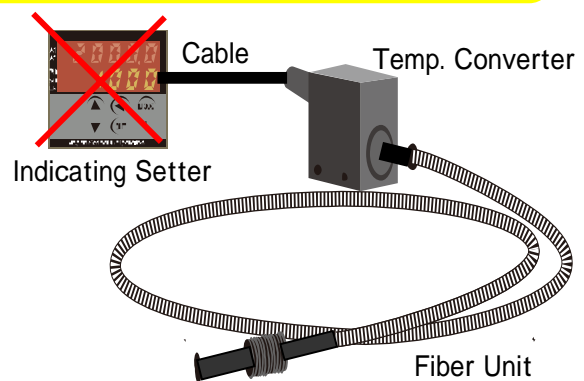

Applications

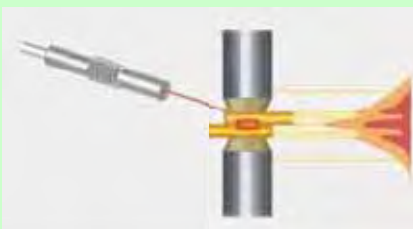

Resistance welding (spot)



Microwave burning furnace



Hot metal

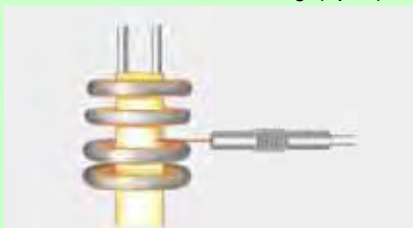

High frequency heating (Coil)



Filament coil

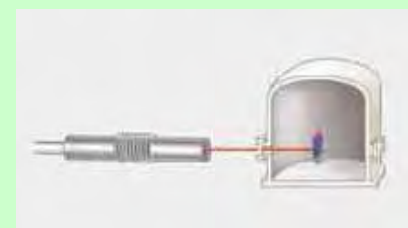

Vacuum Chamber



Volume Sales types

These are low cost models by prescribed specifications.

There are 2 types which can be chosen according to the measuring temp. ranges.

General types (Special Specs. can be accepted)

99types of combination selectable by sensor head only.

(Please refer to Page 3.)

Specifications of Volume Sales types

Model (sensor unit only)	FTK9-P300 -10R21	FTK9-A600 -30R21
Model (sensor unit with indicating setter)	FTZ9-P300R-10R21-EPN	FTZ9-A600R-30R21-EPN
Temp. measuring range	300 ~ 2000	600 ~ 2000
Measuring distance	100mm	300mm
Target size	1.8mm	4.0mm
Spectral response (element)	0.8 ~ 1.6 μ m (InGaAs)	0.8 ~ 1.0 μ m (Si)
Fiber length	1m	1m
Sighting	LED sighting	

*1 When you use the sensor unit (FTK9) only, please select the output of temperature converter, **analog output** or **RS232C**. Ordering model : Analog output : **A** RS232C : **R**

Note : When the output of sensor unit is analog output, it cannot be put together with Indicating Setter. (But it can be put together with Parameter Setter Model:PWC1).

For usage of sensor unit only.

The setting is not possible with the sensor unit only. Please change the setting by Handy Type Parameter Setter, Model:PWC1. Choosing RS232C output type, you should program the communication software for the setting by PC (Personal Computer) and/or PLC (Programmable Logic Controller).



Parameter setter
Model :PWC1
(AA battery type)

Peak hold

Peak values can be hold.

You can select 3 kinds of reset functions below;

< Time > Holding is reset after definite time.

< External > Holding is reset by the external timing signal.
(Indicating Setter only.)

Reset timing can be set on rising edge or falling edge .

< Discharge > Level of input value falls at a definite slope.

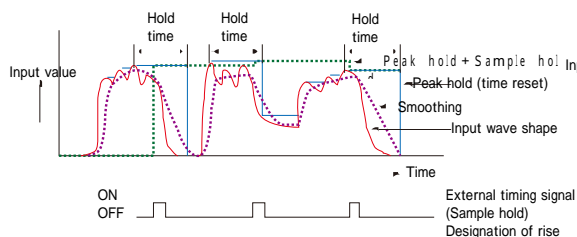

Smoothing

Temperature indication is averaged by setting of smoothing.

Sample hold (Indicating Setter only)

The measured value is hold when the external timing signal is input.

The timing can be set on rising edge or falling edge.

This function can be used together with Peak hold too.

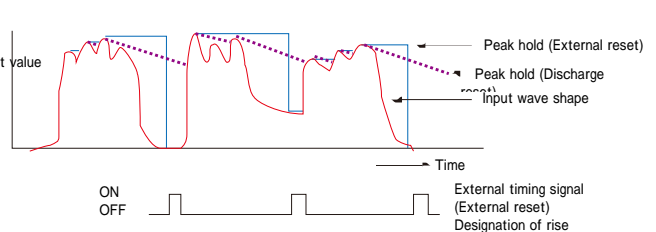

SPECIFICATIONS

Temperature converter

Accuracy (*1) Refer to Note 1	Under 800 : ± 4 800 ~ 1,200 : Measured value $\pm 0.5\%$ 1200 ~ 2000 : Measured value $\pm 1.0\%$
Repeatability (*1)	$\pm 0.2\% \pm 2$
Measuring (*1) resolution	Under min. temperature +50 : less than 3 Under min. temperature +100 : less than 1 More than min. temperature +100 : less than 0.5
Response time	0.001 ~ 600sec changeable (0 ~ 95% analog output) 0.003 ~ 600sec changeable (RS232C temp. output) (*2) (At the change of inner range, addition 0.001sec)
Parameter setting	By Indicating Setter and Parameter setter(PWC).
Material of case	Polycarbonate resin
Ambient temp.	0 ~ 70 (Cable : 105) Laser sighting : 0 ~ 50
Ambient humidity	30 ~ 85% RH (without dew drop)
Storage temp.	-15 ~ 80
Supply voltage	DC4.7 ~ 27V, 0.5VA (*3)
Warm up Time	1 minutes

Fiber

Diameter of Fiber core	0.1mm	0.2mm	0.6mm
Bending radius of fiber	40mm	50mm	150mm
Material of fiber	Quartz		
Heat resistance	150		
Protect tube of fiber	SUS hose		

Sensor head

Material of head	Aluminium(surface is blacked)
Heat resistance	150

- (*1) at Environmental Temp. 23 ± 5 , emissivity 1.0, smoothing time of 0.05sec
 (*2) When cable length is over 10m, response time becomes more than 0.003sec.
 (*3) Lower limit voltage is when analog output(0 ~ 1V) or RS232C output at the cable length 2m.

Indicating Setter

Model	TMC9-E	
Form	Panel mount	
Supply voltage	DC10 ~ 27V, less than 1.2VA	
Communication with Temp. converter	RS232C (Output swing width $\pm 4V$)	
Emissivity	Guaranteed range 0.3 ~ 1.0 (With Reflex calibration function) Setting range 0.050 ~ 1.000(Setting resolution 0.001) Option Function of setting by external analog input is equipped. (0 ~ 5V corresponds to emissivity 0 ~ 1.0)	
Analog output (Option) See Note 1	Changeable to 0 ~ 1V, mV/ , 0 ~ 20mA, 4 ~ 20mA with Scaling function Optional output : 0 ~ 5V, 0 ~ 10V	
Alarm output	1 point, hysteresis setting width:Temperature range 0 ~ $\pm 5\%$, resolution 0.1% Photo coupler DC30V, 0.2A max. Option · Relay contact Alarm output1 : AC125V, 0.3A max. Alarm output2 : AC250V, 1A max.	
Peak hold	Reset function (selection)	Time : 0.01 ~ 10sec changeable Discharge : time 0.01 ~ 10sec, Level 0.20 ~ 1.00 Option External signal : dry contact or open collector
Sample hold(Optional)	External timing signal input: dry contact or open collector	
Sensor calibration function	Span : 0.50 ~ 1.50 Zero : -50.0 ~ +50.0 (° F)	
Selection of indication measuring mode	Upper display : temp./alarmH/alarmL/blank Lower display : temp. unit/emssivity/alarmH/alarmL/blank	
Self-diagnosis	Internal supply voltage, Temperature converter abnormality	
Display resolution	Changeable to 1 or 0.1	
Indication unit	Changeable to or ° F	
Ambient temp.	0 ~ 50	
Ambient humidity	30 ~ 85% RH (without dew drop)	
Storage temp.	-15 ~ 50	

Note 1

	Output effective range	Analog output error
0 ~ 1V	More than 30mV	$\pm 1.5mV$
mV/	More than 30mV(30)	$\pm 1.5mV$
0 ~ 20mA	More than 0.2mA	$\pm 0.02mA$
4 ~ 20mA	More than 4.0m	$\pm 0.02mA$

TEMPERATURE CONVERTER & INDICATING SETTER

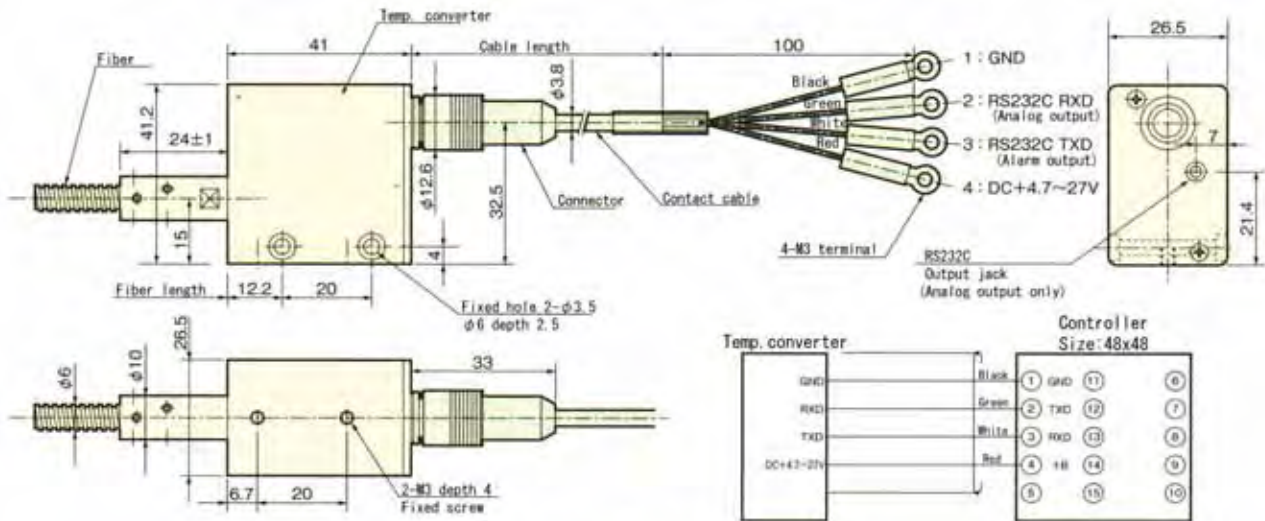

Indicating Setter (Panel mount type)

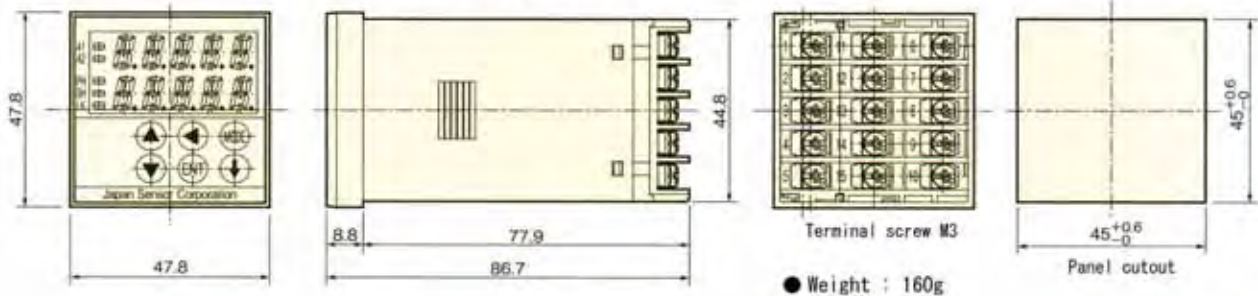

SENSOR HEAD

1 6Lens Round head R

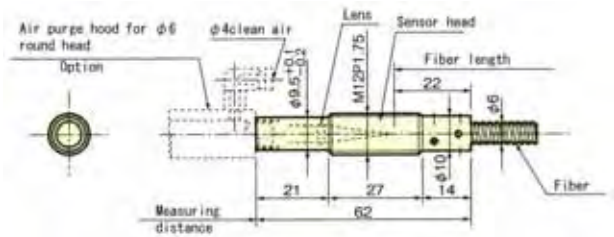

Weight : 15g

5 15Lens Square head B

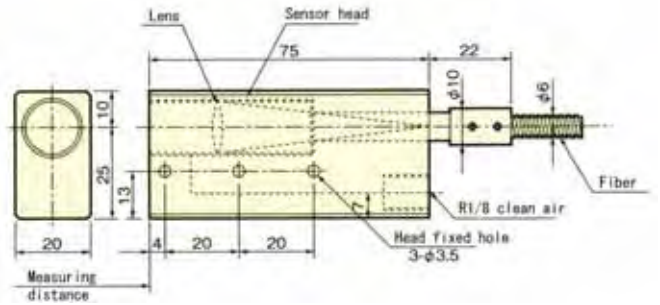

Weight : 130g

2 6Lens Square head S

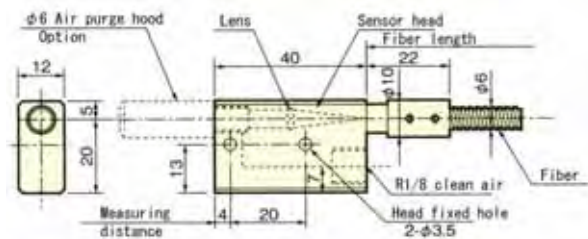

Weight : 30g

6 15Lens Optical sight head L

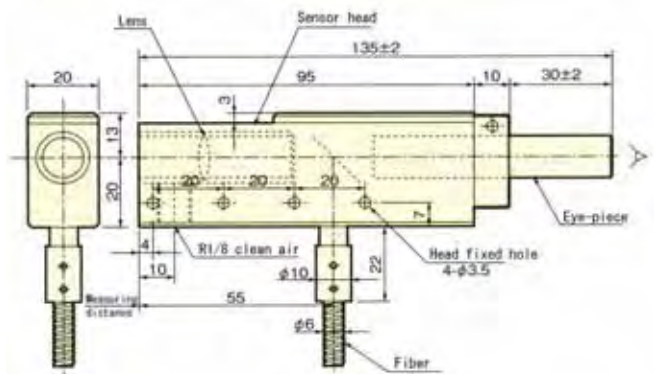

Weight : 160g

3 6Lens Optical sight head K

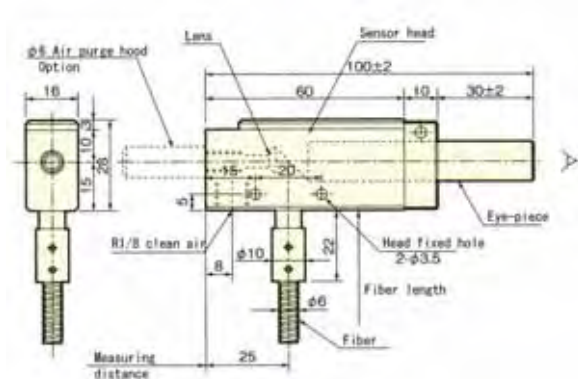

Weight : 80g

7 25Lens Square head H

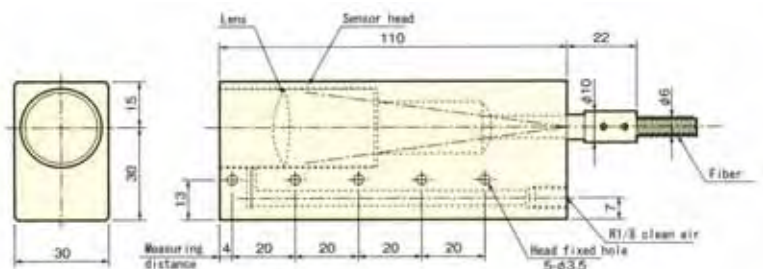

Weight : 350g

4 Wide Angle head A

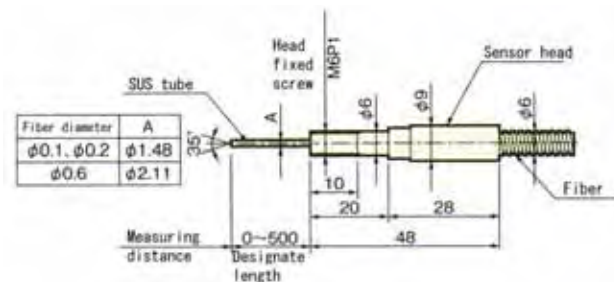

Weight : 5g

8 25Lens Optical sight head G

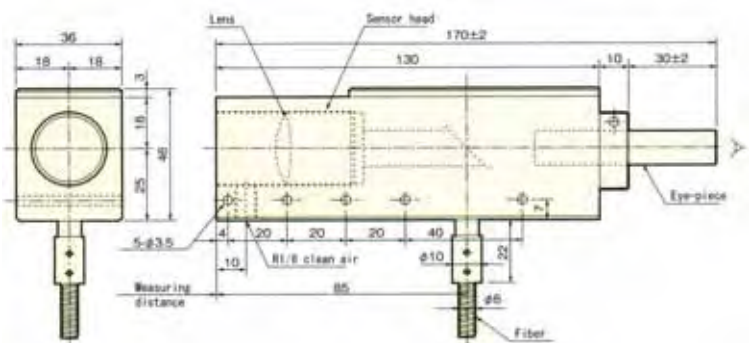

Weight : 500g

WIRING DRAWING (INDICATING SETTER)

Standard type

Alarm output 1 only (Alarm output 1 is photo coupler isolated)

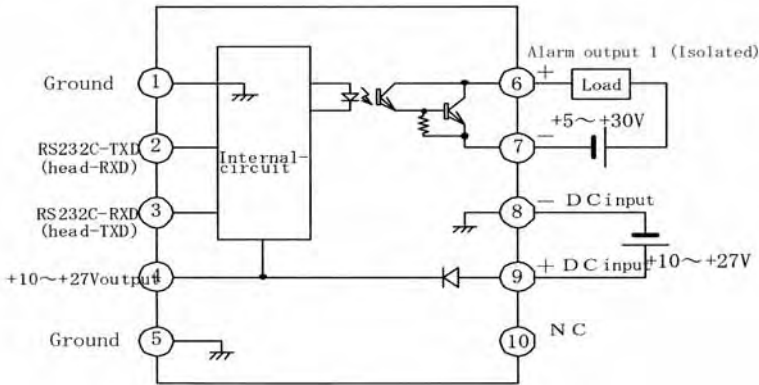

* When the alarm output changes to Relay contact;-

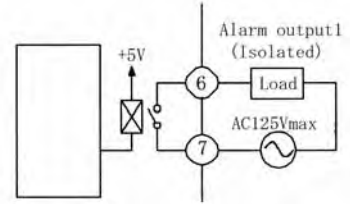

Output option B

Output : Analog output 1, External emissivity
External timing, Alarm output 2

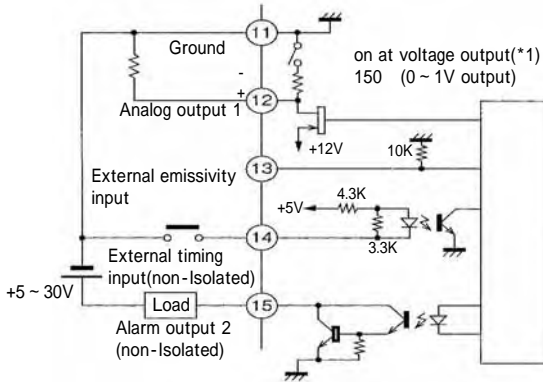

Output option A

Output : Analog output 1, Analog output 2
External timing, Alarm output 2

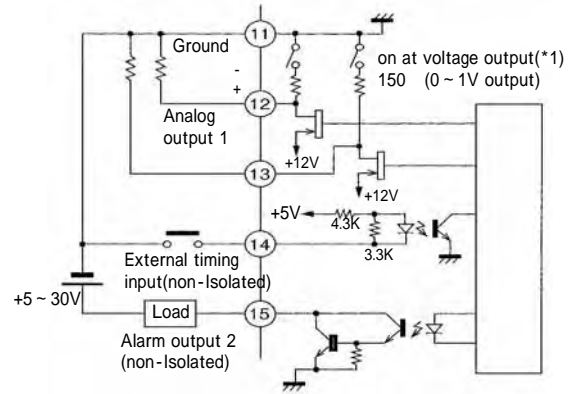

Output option R

Output : Analog output 1, External emissivity
Alarm output 2(relay contact)

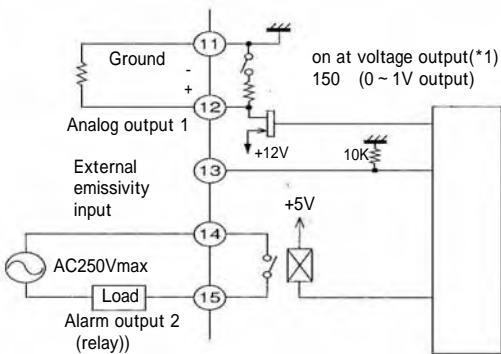

Output option P

Output : Analog output 1, External emissivity
Alarm output 2(photo coupler isolated)

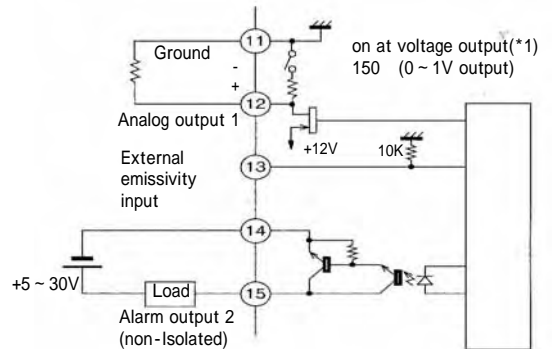

*1 By switching of analog output type, 150 load is on/off.

0 ~ 1V/mV : ON
0 ~ 20mA/4 ~ 20mA : OFF

WIRING DRAWING (SENSOR UNIT)

Analog output

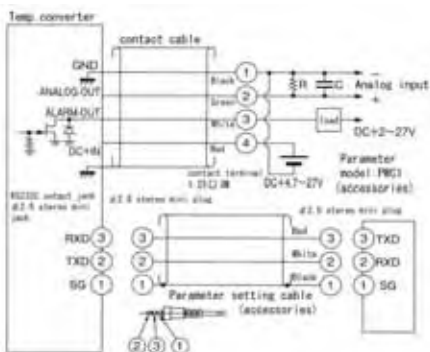

Output	Output type	R	Voltage
0 ~ 1V	0 ~ 1V	150	Over 4.7V
0 ~ 5V	0 ~ 20mA	250	Over 8V
0 ~ 10V	0 ~ 20mA	500	Over 13V
mV/	mV/	150	Over 4.7V
4 ~ 20mA	4 ~ 20mA	-	-
0 ~ 20mA	0 ~ 20mA	-	-

Supply power DC+4.7 ~ 27V connect with cable No.4+, No.1- .
Analog output comes from cable No.2+ and No.1- .
In case the output of 0 ~ 1V or mV/ output, put resistor and capacitor with the end terminals cable.

RS232C output

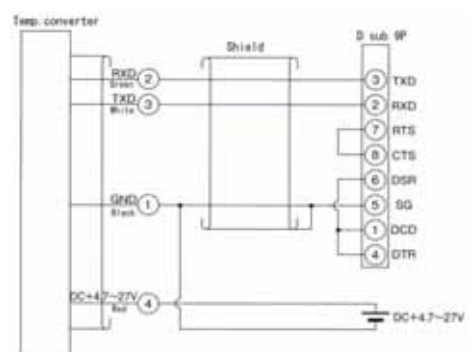

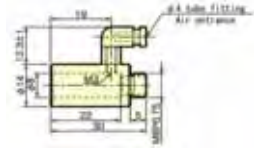
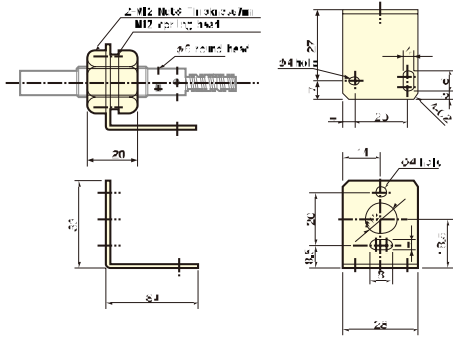

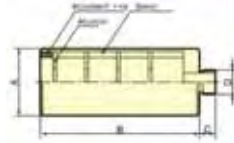
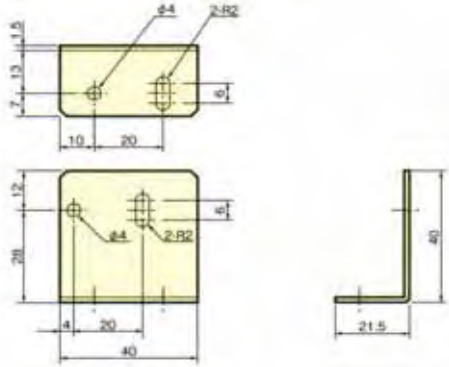

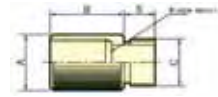



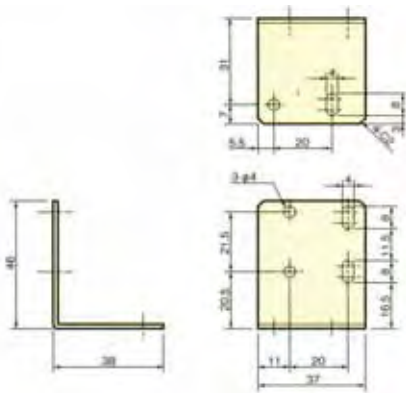
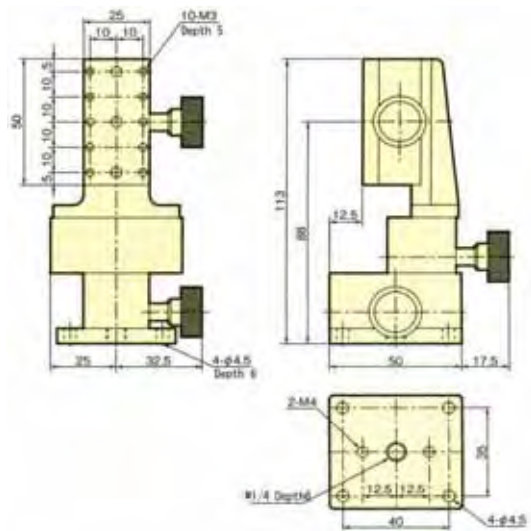
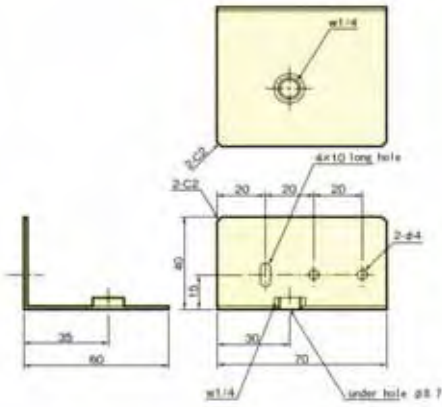

TASHIKA CO., LTD.

1-12, Kaiyo-cho, Ashiya, 659-0035, JAPAN

Tel: + 81-797-23-9035 Fax: + 81-797-23-2105

e-mail: sales@tashika.co.jp URL: www.tashika.co.jp