

Aspirator Block for Oxygen Sensor TB-II G



Aspirator block Introduction

The aspirator block is a suction equipment of the sample gas.

It combines with the sampling probe as the sample introduction pipe.

At first TB-II G sensor should be screwed into the sensor port.

It is installed in the short-pipe and the flange which was built in the measuring point and introduce air. Then the sample gas is sucked from the tip of probe.

There are two ways to emit the sample gas. The one is to release to the atmosphere, the other is to return into the furnace. And it is possible to select them according to the facilities.

It is possible to install at the level - the vertical angle.

※Please consider about the length of short-pipe so that the temperature of the sample gas is less than 350°C in the sensor installation point.

Features

- ◎ It is possible to use in the high temperature condition.
- ◎ It is possible to select vent type or return type.
- ◎ Simple structure, easy maintenance at the site.

Specification

Material	Return type : SUS316L / Release to atmosphere type : SUS316
Installation	Return type : JIS5K65A~ / Release to atmosphere type : JIS5K40A~
Sample gas temp.	It follows to the specification of probe
Sample gas pressure	Return type : ± 5 kPa / Release to atmosphere type : -0.1 kPa~1kPa
Tubing	Rc1/4

TYPE	A B C AB-□-□□-□□-□
A. Type	1: Vent type 2: Return type
B. Flange size	Ex. JIS5K65A:05-65
C. Heater for aspirator block	0: No need 1: Need (Only return type)

Dimension

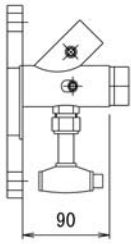
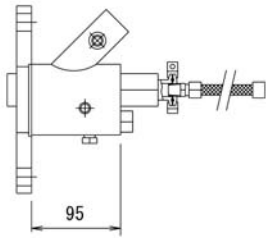
Vent type	Return type
	

Sampling probe

Introduction

The sampling probe is a gas introduction pipe to the aspirator block. It is fixed in the sample entrance of the aspirator block. Choose probe material according to the sample gas temperature condition.

TYPE	A B SP-□□□-□□□□
A. Material	316 : SUS316 (700°Cmax) 310 : SUS310 (900°Cmax) SiC : AirtightnessSiC (1500°Cmax)
B. Length	Example. 700mm: 「0700」

Dimension

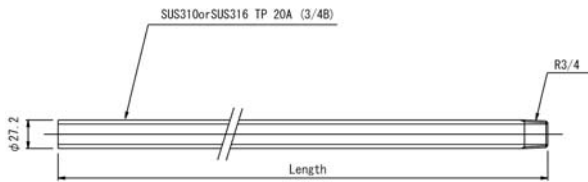
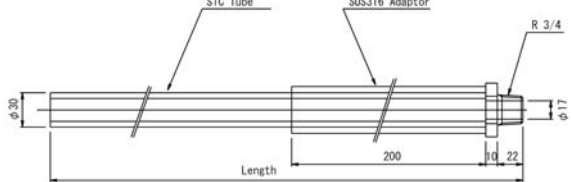
SUS310or316 probe	AirtightnessSiC probe
	

※In case of use except the above, consult separately.

Air supply unit

Instruction

Air supply unit incorporates aspirator air, purge air, SPAN calibration air and standard gas compactly. 2 types can be chosen from to the style which is convenient for into the existing box built-in or the indoor on the wall. Choose according to the installation site.

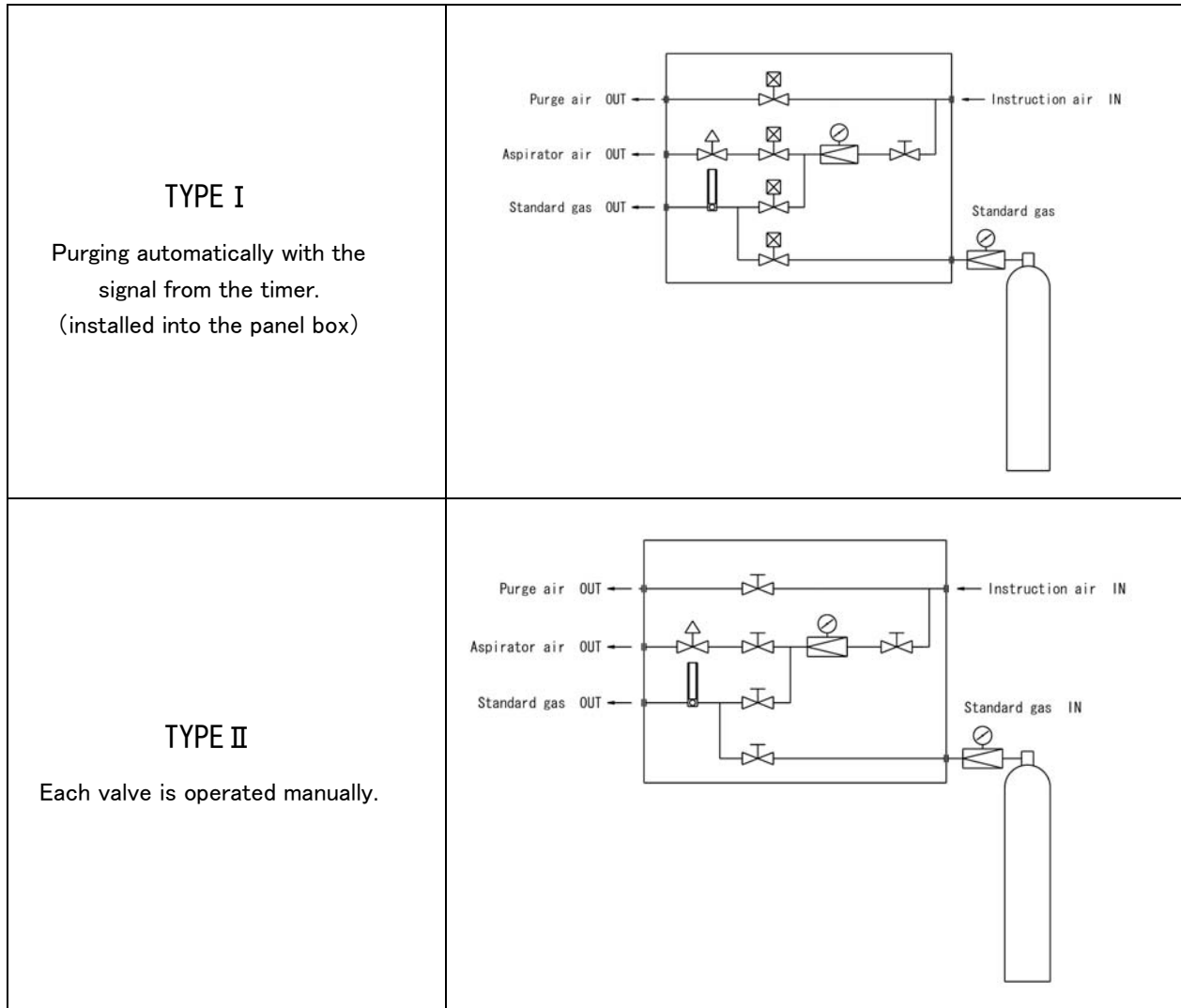

TYPE	A B	
		ABC-2-□-□
A. Type	1. Automatic purge 2. Manual purge	
B. Installation	1. Plate 2. Exclusive box	

Flow diagram

Tubing example

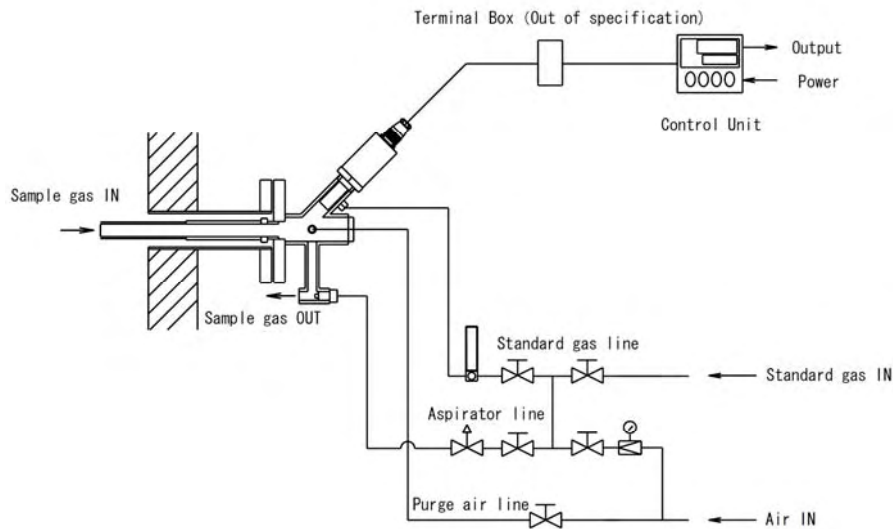

Panel box type example

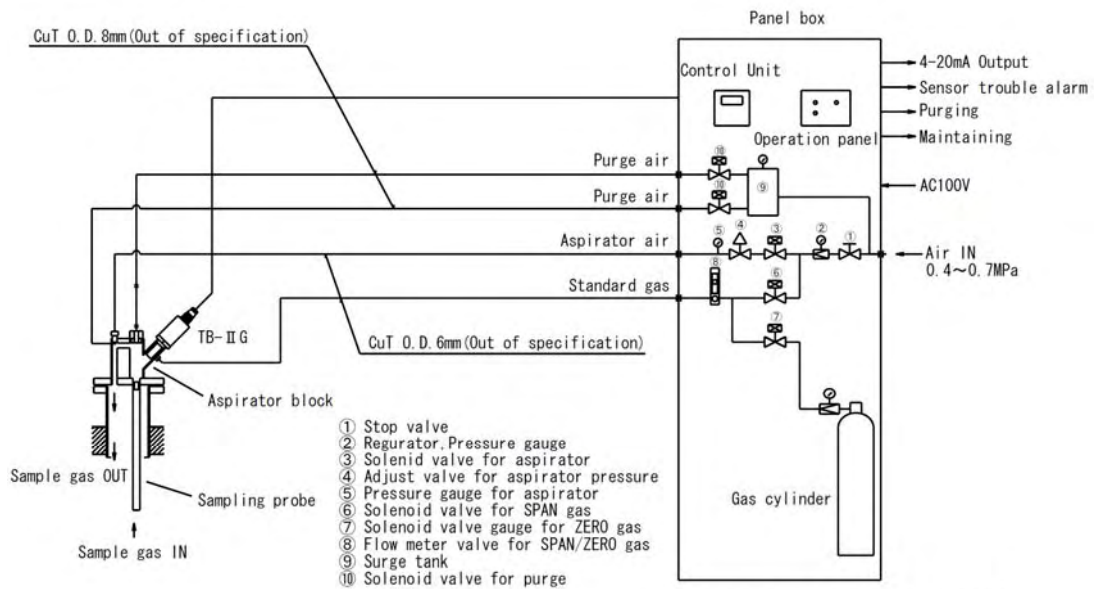

※The installation and the wiring and tubing constructions are out of specification.
 ※All connectings of tubing are Rc1/4.

TASHIKA BOEKI SHOKAI K.K.

1-12, Kaiyo-cho, Ashiya, 659-0035, JAPAN

Tel: + 81-797-23-9035 Fax: + 81-797-23-2105

e-mail: sales@tashika.co.jp URL: www.tashika.co.jp