

HIGH INTENSITY WARNING LAMP

MODEL: VL-17M

FEATURES

- 1 Large emitting area with Wide visibility
- 2 Simulated revolution f light with no vibration
- 3 External switching from revolving to flashing mode
- 4 Highly durable design with long operational life in field
- 5 Model available with option of audio warning alarm or melody through built-in speaker
- 6 Environmentally friendly with electricity costs 1/3 as compared to normal bulb type warning lamp



Φ170 (LED/Moterless/IP23)

DESCRIPTION

Warning lamp VL-17M utilizes 160 pcs high brightness LEDs as light source poisoned in two tiers to provide wide visibility in a large area. Blue and green color lamps have 128 pcs of LEDs. The lamp uses LEDs consume much lesser electricity as compared to tradition bulbs and have longer life span of 40,000!50,000 hours as compared to life span of 10,000 hours of traditional bulbs. Sequential lighting pattern of LEDs simulates effect of revolving light. The lamp, in fact, is motorless and has completely vibration-less, maintenance free and trouble free operation. Lamp body is made from polycarbonate suitable for prolonged use in outdoor locations.

VL-17M series lamp can be set to either revolving mode or flashing mode. Switching from revolving to flashing mode can be set from remote. Using internal dip switches, revolving mode can be set to fast or slow rotation sped and in flashing mode can be set to flash both tiers of LEDs to flash simultaneously or alternately in sequence. Optional models are available with internal speaker for audio alarm. User can choose from two types of audio warning alarms or two types of audio melodies.

MODEL CONFIGURATION

Example model type)
AC100V, w/o electric sound, Red, Magnet attachment

VL17M-100AR/M



Model

Rated voltage

012: AC/DC12V
024: AC/DC24V
D48: DC48V
100: AC100V
200: AC200V
400: AC400V

Magnet attachment

Color

R: Red
Y: Yellow
G: Green
B: Blue

Function

A: w/o electronic sound
B: w/ electronic sound

TECHNICAL SPECIFICATIONS

Classification	Voltage rating	Model number	light bulb colors	Number of LED	Control input	Electronic sound input	Consumed power	Number of flash light		Range of working voltage	Operating temperature	Mass	Quantity
								Revolving	Blinking				
Large size LED Warning lamp	AC/DC12V	VL17M-012A□/△	Red·Yellow Green·Blue	160 128	●	-	12W	Low speed 100 times/min. High speed 220 times/min.	50 times /min.	10.8~13.2V	-10°C~50°C	790g	4
		VL17M-012B□/△	Red·Yellow Green·Blue	160 128	●	●	15W					830g	
	AC/DC24V	VL17M-024A□/△	Red·Yellow Green·Blue	160 128	●	-	12W			21.6~26.4V		790g	
		VL17M-024B□/△	Red·Yellow Green·Blue	160 128	●	●	15W					830g	
	DC48V	VL17M-D48A□/△	Red·Yellow Green·Blue	160 128	●	-	14W			43.2~52.8V		820g	
		VL17M-D48B□/△	Red·Yellow Green·Blue	160 128	●	●	17W					860g	
	AC100V	VL17M-100A□/△	Red·Yellow Green·Blue	160 128	●	-	9W			90~120V		980g	
		VL17M-100B□/△	Red·Yellow Green·Blue	160 128	●	●	11W					1020g	
	AC200V	VL17M-200A□/△	Red·Yellow Green·Blue	160 128	●	-	9W			180~240V		980g	
		VL17M-200B□/△	Red·Yellow Green·Blue	160 128	●	●	11W					1020g	
	AC400V	VL17M-400A□/△	Red·Yellow Green·Blue	160 128	●	-	9W			360~480V		980g	
		VL17M-400B□/△	Red·Yellow Green·Blue	160 128	●	●	11W					1020g	

[Protective characteristic: IP23(Front direction mounting) Buzzer sound pressure:Up to 70dB(at 1m)]

* The light bulb color's initial letter enters □ part.(R: Red, Y: Yellow, G :Green, B:Blue)

* The magnet attachment letter "M" enters △ part.

* Blinking is given to priority in the revolving and blinking.

* The warning sound is given to priority in the melody

Classification	Name of product	Model number	Remarks
Warning lamp options	Wall mounting bracket	A82709	
	Protection seal for magnet	A90127	The seal attach on the magnet side for using to prevent from scratching the apparatus on the other side. (It needs three seals.)

WIRING DIAGRAM

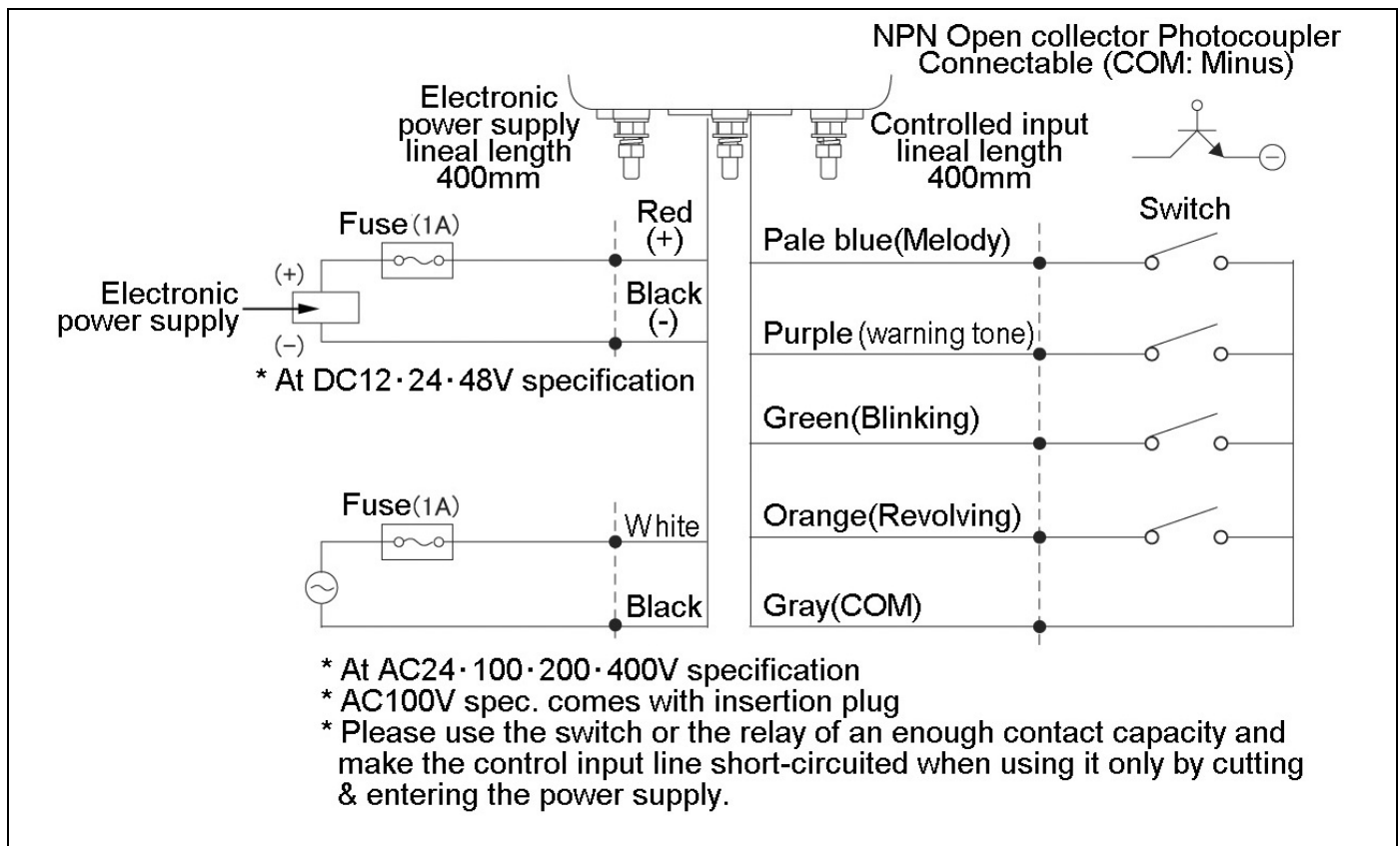

DEMENSIONS

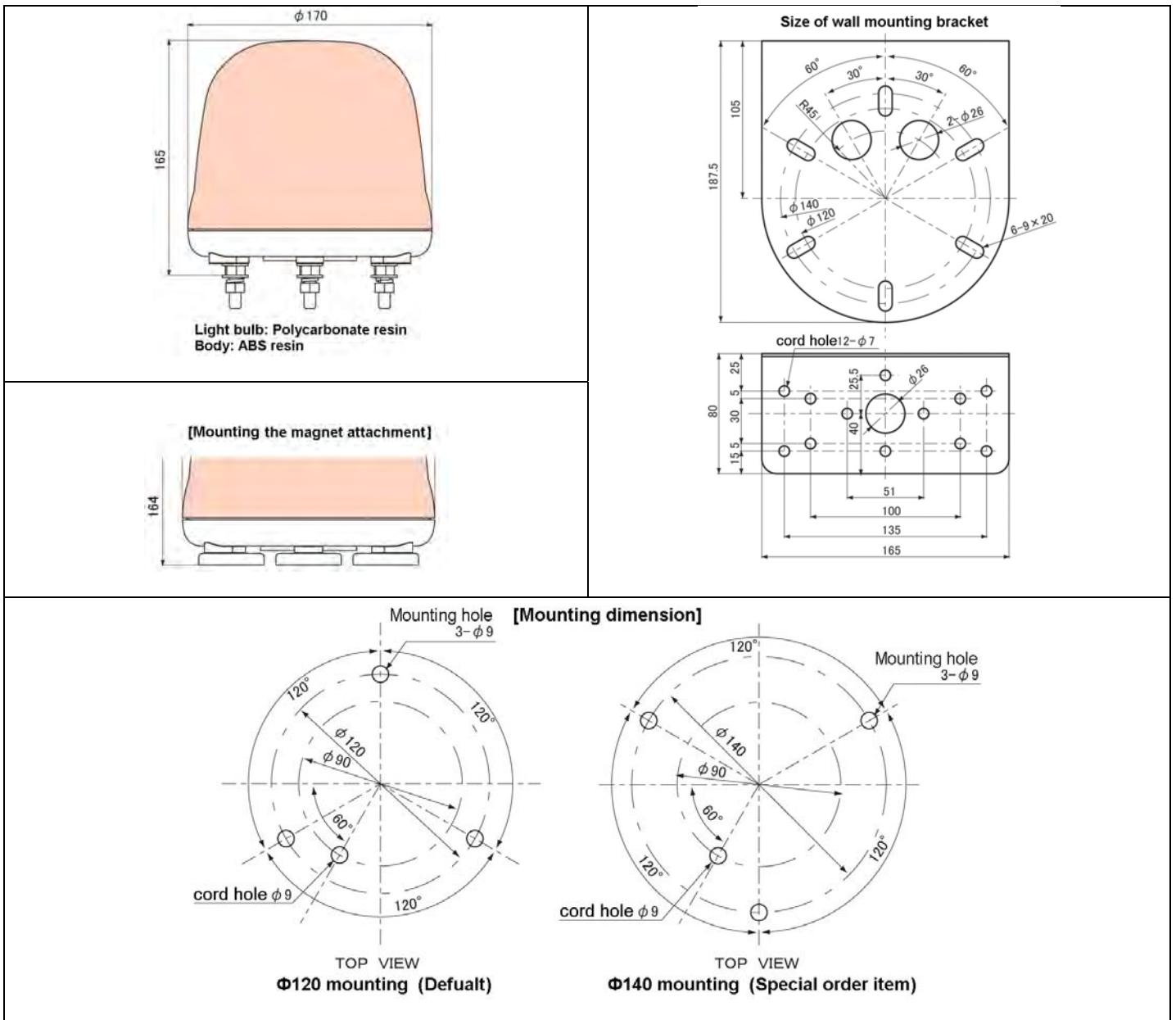

OPTIONAL ACCESSORIES



Wall mounting bracket
A82709



Protection seal for magnet
A90127

DUE TO CONTINUOUS PRODUCT IMPROVEMENT, THE DESIGN AND TECHNICAL SPECIFICATIONS ARE SUBJECT TO CHANGE WITHOUT PRIOR NOTICE

TASHIKA BOEKI SHOKAI K.K.

1-12, Kaiyo-cho, Ashiya, 659-0035, JAPAN

Tel: + 81-797-23-9035 Fax: + 81-797-23-2105

e-mail: sales@tashika.co.jp URL: www.tashika.co.jp