

%RH

Series SR1 / SR3

DIGITAL CONTROLLER

BASIC FEATURES

- Multi-input and multi-range performance
- Large 20mm bright display (SR3)
- Dust and splash proof front panel NEMA4X / IP66



CE approved

ORDERING INFORMATION

ITEM	CODE	SPECIFICATIONS
SERIES	SR1-	MPU-Based Auto-Tuning PID Digital Controller, DIN H48 x W48 x D111mm
	SR3-	MPU-Based Auto-Tuning PID Digital Controller, DIN H96 x W96 x D111mm
INPUT	8	Multi input
		R.T.D.: Pt100/JPt100
	6	Thermocouple: B, R, S, K, E, J, T, N, PLII, WR e5-26 {U, L (DIN 43710)}
Voltage(mV): -10~10, 0~10, 0~20, 0~50, 10~50, 0~100mV DC Voltage (V): -1~1, 0~1, 0~2, 0~5, 1~5, 0~10V DC Current (mA): 4~20mA DC:(V) 0~5V DC (applied via enclosed 250 shunt resistor) Scaling possible Range: -1999~9999 Span: 10~5000		
CONTROL OUTPUT	Y -	Contact 1a Contact capacity: 240V AC 2.0A/resistive load Proportional cycle: 1~120 seconds
	I -	Current 4~20mA DC Load Resistance: 600 max.
	P -	SSR drive voltage 12V ±1.5V DC 30mA max. Proportional cycle:1~120 seconds
	V -	Voltage 0~10V DC Load current: 2mA max.
EVENT OUTPUT	1	Event output (1a) x 2 points, Contact capacity: 240V AC 1A/resistive load
REMARKS	W	Without
	X	With (Please consult before ordering.)

MEASURING RANGE CODES

Type of input	Code	Scaling range			
Thermocouple	B *1	01	0 ~ 1800 C	0 ~ 3300 F	
	R	02	0 ~ 1700 C	0 ~ 3100 F	
	S	03	0 ~ 1700 C	0 ~ 3100 F	
	*3	K	04	199.9 ~ 400.0 C	300 ~ 750 F
			05	0.0 ~ 800.0 C	0 ~ 1500 F
		06	0 ~ 1200 C	0 ~ 2200 F	
	E	07	0 ~ 700 C	0 ~ 1300 F	
	J	08	0 ~ 600 C	0 ~ 1100 F	
	T *3	09	199.9 ~ 200.0 C	300 ~ 400 F	
	N	10	0 ~ 1300 C	0 ~ 2300 F	
	PLII *4	11	0 ~ 1300 C	0 ~ 2300 F	
	WR e5-26*5	12	0 ~ 2300 C	0 ~ 4200 F	
	U *2, *3	13	199.9 ~ 200.0 C	300 ~ 400 F	
	L *2	14	0 ~ 600 C	0 ~ 1100 F	
R.T.D.	Pt100	31	200 ~ 600 C	300 ~ 1100 F	
		32	100.0 ~ 100.0 C	150.0 ~ 200.0 F	
		33	50.0 ~ 50.0 C	50.0 ~ 120.0 F	
		34	0.0 ~ 200.0 C	0.0 ~ 400.0 F	
	JPt100	35	200 ~ 500 C	300 ~ 1000 F	
		36	100.0 ~ 100.0 C	150.0 ~ 200.0 F	
		37	50.0 ~ 50.0 C	50.0 ~ 120.0 F	
		38	0.0 ~ 200.0 C	0.0 ~ 400.0 F	

Type of input	Code	Scaling range
Voltage (mV)	10 ~ 10	71
	0 ~ 10	72
	0 ~ 20	73
	0 ~ 50	74
	10 ~ 50	75
Voltage (V)	0 ~ 100	76
	1 ~ 1	81
	0 ~ 1	82
	0 ~ 2	83
	0 ~ 5	84
	1 ~ 5	85
	0 ~ 10	86

Note: *1 Thermocouple B: Accuracy guarantee not applicable Temp. below 400 C.
 *2 Thermocouple U, L: DIN 43710
 *3 Thermocouple K, T, U: Accuracy guarantee not applicable Temp. below -100 C. (1.0%FS+1digit)
 *4 Thermocouple PLII: Platinel
 *5 Thermocouple WR e5-26: A product of Hoskins

*Unless otherwise specified, following setting will be applied for shipment.

Input	Specification/Rating	Measuring range
Multi input	K thermocouple	0.0 ~ 800.0 C
Voltage (V)	0 ~ 10V DC	0.0 ~ 100.0

Control Output	Control Mode
Y	ON-OFF (P=OFF)
I, P, V	PID Control (P=3.0)

SPECIFICATIONS

Series SR1 / SR3

Model
 SR1: 48 x 48 Digital Controller
 SR3: 96 x 96 Digital Controller

Display
 Digital display SR1: (PV)/4 digit 7 segments red LED (H: 11mm)
 (SV)/4 digit 7 segments green LED (H: 9.5mm)
 SR3: (PV)/4 digit 7 segments red LED (H: 20mm)
 (SV)/4 digit 7 segments green LED (H: 13mm)

Display accuracy: $\pm(0.3\%FS + 1 \text{ digit})$ (see "Note" in Measuring Range Codes)
 (Excluding cold junction compensation accuracy)

Display accuracy maintaining range:
 23°C \pm 5°C

Display resolution: Depends on measuring range (0.001, 0.01, 0.1, 1)
 Display updating cycle: 0.5 seconds
 Action display: 5 LED lamp displays (OUT/EV1/EV2/AT/MAN)

Setting
 Setting method: By operating 4 keys (∇ , \blacktriangle , ENT, \odot) (front panel)
 Target value setting range:
 Same as measuring range (within setting limiter)
 Setting limiter: Individual setting for higher & lower limits are possible
 within measuring range (Lower limit value < Higher limit value)

Input
 Type of input: Selectable from multiple (TC, Pt, mV) and voltage (V)
 *Current input 0-20mA DC (Voltage: 0-5V), 4-20mA DC
 (Voltage: 1-5V) applied via 250 Ω shunt resistor
 Thermocouple: B, R, S, K, E, J, T, N, PL II, WR e5-26, {U, L (DIN 43710)}
 Input impedance: 500k minimum
 External resistance tolerance:
 100 maximum
 Burnout function: Standard feature (up scale)
 Cold junction compensation accuracy:
 $\pm 1^\circ\text{C}$ (within 23°C \pm 5°C)
 $\pm 2^\circ\text{C}$ (ambient temperature: 5°C to 45°C)

R.T.D.: Pt100/JPt100, 3-wire type
 Amperage: 0.25 mA
 Lead wire tolerance: Lead wire tolerance: 5 maxi/wire
 (3 lead wires should have the same resistance.)

Voltage mV: -10~-10, 0~-10, 0~-20, 0~-50, 10~-50, 0~-100mv DC
 (Burnout) Up scale at time of abnormal input
 V: -1~-1, 0~-1, 0~-2, 0~-5, 1~-5, 0~-10V DC

Input impedance: 500k minimum
 Input scaling function: Scaling possible for voltage (mV, V) or current (mA) input
 Scaling range: -1999~9999 counts
 Span: 10~5000 counts
 Decimal point: (Position) None, 0.0, 0.00, 0.000
 Sampling cycle: 0.5 seconds
 PV bias: -1999~2000 units
 PV filter: 0~100 seconds
 Isolation: Insulated between input and output (not insulated
 between input and system)

Control
 Control mode: Expert PID control with auto tuning function
 Proportional band (P): OFF, 0.1~999.9% (ON-OFF action by OFF)
 Integral time (I): OFF, 1~6000 seconds (P or PD action by OFF)
 Derivative time (D): OFF, 1~3600 seconds (P or PI action by OFF)
 Manual reset: -50.0~50.0% (Effective when I=OFF)
 ON-OFF hysteresis: 1~999 units (Effective when P=OFF)
 Proportional cycle: 1~120 seconds (for contact and SSR drive voltage output)

Control output characteristic:
 RA (reverse action characteristic)/DA (direct action
 characteristic) is selectable (Default setting =RA)
 *P=OFF by default for contact output, others: PID control

Type of control/rating:
 Contact: 1a 240V AC 2A (resistive load)
 SSR drive voltage: 12V \pm 1.5V DC (Max load current 30mA)
 Voltage: 0~10V DC (Max load current 2mA)
 Current: 4~20mA DC (Max load resistance 600 Ω)
 Control output resolution: Approx. 0.5% (1/200)
 Isolation: Output is isolated from all

Event output
 Number of events: Total 2 points of EV1 and EV2 as standard
 Type: Selectable from the following 8 types for EV1 and EV2:
 No selection, Higher limit deviation, Lower limit deviation,
 Outside higher/lower limit deviations, Within
 higher/lower limit deviations, Higher limit absolute value,
 Lower limit absolute value, Scale over

Event setting range: Absolute values: (both higher limit and lower limit): Within
 measuring range, Deviations: (both higher limit and
 lower limit): -1999~2000 units, Higher/lower limit
 deviations (within/outside): 0~2000 units

Event action:
 Hysteresis: 1~999 units
 Standby action: Selectable from the following 4 types
 (EV1 and EV2)
 (1) None. (2) Standby when power is applied. (3) Standby
 when power is applied and when SV value in execution
 is changed. (4) Control mode without standby action
 (No alarm is output at the time of abnormal input).

Output type/rating: Contact (1a x 2 points common)/240V AC 1A (resistive load)
 Output updating cycle: 0.5 seconds
 Action display: 2 LED lamp displays (EV1/EV2)

General Specifications
 Data storage: Non-volatile memory (EEPROM)
 Operating conditions: (Ambient temperature) -10~50 °C
 (Ambient humidity) 90%RH or less (no dew condensation)
 (Altitude) 2000m from the sea level or lower
 (Category) II, (Degree of pollution) 2

Storage temperature: -20~65°C
 Supply voltage: 100-240V AC \pm 10% 50/60Hz
 Power consumption: 10VA 240V AC, 6VA 100V AC
 Input/noise removal ratio: (Normal mode) 40 dB or higher (50/60 Hz)
 (Common mode) 120 dB or higher (50/60 Hz)
 For Voltage (V) input: 90 dB or higher (50/60 Hz)

Applicable standards:
 Safety: IEC 61010 and EN 61010-1
 EMC: EN 61326 (Class A: Industrial environment)

Insulation resistance: Input/output - power supply: 500V DC 20M Ω or above
 Input/output - contact output: 500V DC 20M Ω or above
 Dielectric strength: Input/output - power supply: 2300V AC 1 minute
 Contact output - power supply: 2300V AC 1 minute
 Protective structure: Only front panel has dust-proof and drip-proof structure
 NE MA4X and IP66

Material / Color of case: PPO resin molding (equivalent to UL94V-1) / Black
 External dimensions: SR1: H48 x W48 x D111 (Panel depth: 100) mm
 SR3: H96 x W96 x D111 (Panel depth: 100) mm
 Mounting: Push-in panel (one-touch mount)
 Panel thickness: 1.0~4.0 mm
 Panel cutout / Weight: SR1: H45 x W45 mm / Approx. 150 g
 SR3: H92 x W92 mm / Approx. 270 g

SR1

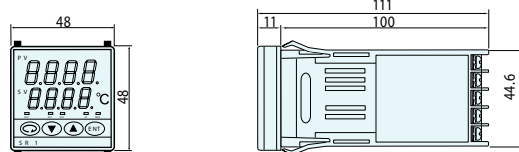

External Dimensions

Panel Cutout

SR1

SR3

Terminal Arrangement

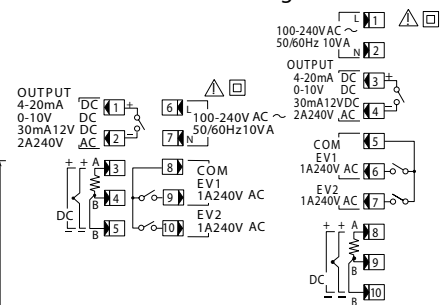

Unit: mm

SR3

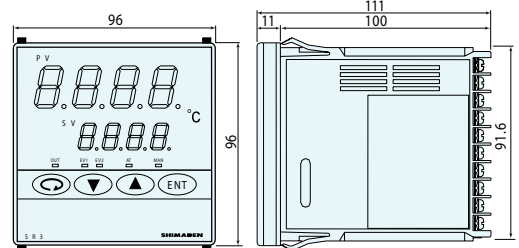

TERMINAL COVER (AVAILABLE SEPARATELY)

Material: PVC, Appearance: transparent, Thickness: 1 mm

Model	Terminal Cover (P/N)	Mounting
SR1	QCR001	One-touch mount
SR3	QCR006	One-touch mount

Warning ⚠ The SR1/SR3 series are designed for the control of temperature, humidity and other physical values for the general industrial equipment. It is not to be used for any purpose which regulates the prevention of serious effects on human life or safety. No warranty, express or implied is valid if used without proper safety measures.

Caution ⚠ If the possibility of loss or damage to your system or property as a result of failure of any part of the process exists, proper safety measures must be made before the instrument is put into use as to prevent the occurrence of trouble.

(The contents of this brochure are subject to change without notice.)

DOE TO CONTINUOUS PRODUCT IMPROVEMENT, THE DESIGN AND TECHNICAL SPECIFICATIONS ARE SUBJECT TO CHANGE WITHOUT PRIOR NOTICE.

TASHIKA BOEKI SHOKAI K.K.

1-12, Kaiyo-cho, Ashiya, 659-0035, JAPAN

Tel: + 81-797-23-9035 Fax: + 81-797-23-2105

e-mail: sales@tashika.co.jp URL: www.tashika.co.jp

ISO 9001

